

# Installation Note

---

## Add 4-Port Capability Upgrade Kit

To Upgrade PNA-X N5244A or N5245A Option 219 to Option 419

Upgrade Kit Order Numbers: N5244AU- 942 and N5245AU- 942



Agilent Kit Number: N5245-60106  
Agilent Document Number: N5245-90012  
Printed in USA January 27, 2010  
Supersedes print date: November 16, 2009  
© Agilent Technologies, Inc. 2009–2010



---

## WARRANTY STATEMENT

THE MATERIAL CONTAINED IN THIS DOCUMENT IS PROVIDED “AS IS,” AND IS SUBJECT TO BEING CHANGED, WITHOUT NOTICE, IN FUTURE EDITIONS. FURTHER, TO THE MAXIMUM EXTENT PERMITTED BY APPLICABLE LAW, AGILENT DISCLAIMS ALL WARRANTIES, EITHER EXPRESS OR IMPLIED WITH REGARD TO THIS MANUAL AND ANY INFORMATION CONTAINED HEREIN, INCLUDING BUT NOT LIMITED TO THE IMPLIED WARRANTIES OF MERCHANTABILITY AND FITNESS FOR A PARTICULAR PURPOSE. AGILENT SHALL NOT BE LIABLE FOR ERRORS OR FOR INCIDENTAL OR CONSEQUENTIAL DAMAGES IN CONNECTION WITH THE FURNISHING, USE, OR PERFORMANCE OF THIS DOCUMENT OR ANY INFORMATION CONTAINED HEREIN. SHOULD AGILENT AND THE USER HAVE A SEPARATE WRITTEN AGREEMENT WITH WARRANTY TERMS COVERING THE MATERIAL IN THIS DOCUMENT THAT CONFLICT WITH THESE TERMS, THE WARRANTY TERMS IN THE SEPARATE AGREEMENT WILL CONTROL.

---

## DFARS/Restricted Rights Notice

If software is for use in the performance of a U.S. Government prime contract or subcontract, Software is delivered and licensed as “Commercial computer software” as defined in DFAR 252.227-7014 (June 1995), or as a “commercial item” as defined in FAR 2.101(a) or as “Restricted computer software” as defined in FAR 52.227-19 (June 1987) or any equivalent agency regulation or contract clause. Use, duplication or disclosure of Software is subject to Agilent Technologies’ standard commercial license terms, and non-DOD Departments and Agencies of the U.S. Government will receive no greater than Restricted Rights as defined in FAR 52.227-19(c)(1-2) (June 1987). U.S. Government users will receive no greater than Limited Rights as defined in FAR 52.227-14 (June 1987) or DFAR 252.227-7015 (b)(2) (November 1995), as applicable in any technical data.

---

## Safety Notes

The following safety notes are used throughout this document. Familiarize yourself with each of these notes and its meaning before performing any of the procedures in this document.

---

<b>WARNING</b>	<b>Warning denotes a hazard. It calls attention to a procedure which, if not correctly performed or adhered to, could result in injury or loss of life. Do not proceed beyond a warning note until the indicated conditions are fully understood and met.</b>
----------------	---

---

<b>CAUTION</b>	Caution denotes a hazard. It calls attention to a procedure that, if not correctly performed or adhered to, could result in damage to or destruction of the instrument. Do not proceed beyond a caution sign until the indicated conditions are fully understood and met.
----------------	---

---

---

## Description of the Upgrade

This upgrade converts your N5244A or N5245A Option 219 2-port analyzer to a N5244A or N5245A Option 419 4-port analyzer by adding:

- an additional source
- an additional source synthesizer
- two additional doublers
- an additional mixer brick
- two additional reference couplers
- two additional test port couplers
- two additional bias tees
- two additional source attenuators
- two additional receiver attenuators
- a splitter
- a modified front panel
- many new cables

---

## Getting Assistance from Agilent

Installing this upgrade kit requires special skills and experience. If you think you may not be qualified to do the work, or need advice, contact Agilent.

### Contacting Agilent

Assistance with test and measurements needs and information on finding a local Agilent office are available on the Web at:

<http://www.agilent.com/find/assist>

If you do not have access to the Internet, please contact your Agilent field engineer.

---

<b>NOTE</b>	In any correspondence or telephone conversation, refer to the Agilent product by its model number and full serial number. With this information, the Agilent representative can determine whether your product is still within its warranty period.
-------------	---

---

---

## Getting Prepared

To successfully install this upgrade kit, you will need the following:

- A license key - refer to “[License Key Redemption](#)” below.
- A PDF copy or a paper copy of the PNA Service Guide - refer to “[Downloading the Online PNA Service Guide](#)” below.
- An ESD-safe work area - refer to “[Protecting Your Workspace from Electrostatic Discharge](#)” below.
- Correct tools - refer to “[Tools Required for the Installation](#)” on page 5.
- Enough time - refer to “[About Installing the Upgrade](#)” on page 6.
- Test equipment for the post-upgrade adjustments and full instrument calibration. To view the equipment list, click the Chapter 3 bookmark “Tests and Adjustments” in the PDF Service Guide<sup>1</sup>.

## License Key Redemption

---

**NOTE** The enclosed Option Entitlement Certificate is a receipt, verifying that you have purchased a licensed option for the PNA of your choice. You must now use an Agilent Web page to request a license key for the instrument that will receive the option.

---

To enable the option product, you must request a license key from: <http://www.agilent.com/find/softwarelicense>. To complete the request, you will need to gather the following information:

- From the certificate
  - Order number
  - Certificate number
- From your instrument
  - Model number
  - Serial number
  - Host ID

The instrument information is available on the network analyzer – on the analyzer’s **Help** menu, click **About Network Analyzer**.

If you provide an email address, Agilent will promptly email your license key. Otherwise, you will receive your license key via postal mail.

---

1. See “[Downloading the Online PNA Service Guide](#)” on page 5.

## Downloading the Online PNA Service Guide

To view the online Service Guide for your PNA model number, use the following steps:

1. Go to [www.agilent.com](http://www.agilent.com).
2. In the Search box, enter the model number of the analyzer (Ex: N5245A) and click **Search**.
3. Click [Technical Support > Manuals](#).
4. Click [Service Manual](#).
5. Click the service guide title to download the PDF file.
6. When the PDF of the Service Guide is displayed, scroll through the Contents section bookmarks to locate the information needed.

## Protecting Your Workspace from Electrostatic Discharge

For information, click on the Chapter 1 bookmark, “Electrostatic Discharge Protection” in the PDF Service Guide<sup>1</sup>.

### ESD Equipment Required for the Installation

Description	Agilent Part Number
ESD grounding wrist strap	9300-1367
5-ft grounding cord for wrist strap	9300-0980
2 x 4 ft conductive table mat and 15-ft grounding wire	9300-0797
ESD heel strap (for use with conductive floors)	9300-1308

### Tools Required for the Installation

Description	Qty	Part Number
T-6 TORX driver - set to 4 in-lbs (0.45 N.m)	1	N/A
T-10 TORX driver - set to 9 in-lbs (1.02 N.m)	1	N/A
T-20 TORX driver - set to 21 in-lbs (2.38 N.m)	1	N/A
5/16-in (8 mm) nutsetter or open end torque wrench - set to 10 in-lbs (1.13 N.m)	1	N/A
5/16-in (8 mm) nutsetter or open end torque wrench - set to 21 in-lbs (2.38 N.m)	1	N/A
3/16-in (5 mm) nutsetter or open end torque wrench - set to 6 in-lbs (0.68 N.m)	1	N/A
5/8-in (16 mm) nutsetter or open end torque wrench - set to 21 in-lbs (2.38 N.m)	1	N/A
9 mm nutsetter or open end torque wrench - set to 21 in-lbs (2.38 N.m)	1	N/A
1-in (25.4 mm) torque wrench - set to 72 in-lbs (8.15 N.m)	1	N/A
1/4-in (6 mm) open end wrench	1	N/A

---

**CAUTION** Use a 5/16-in torque wrench set to 10 in-lbs on all cable connections except the front and rear panel cable connectors. On these, use a 9 mm nutsetter or open end torque wrench set to 21 in-lb.

---

## About Installing the Upgrade

Products affected . . . . .	N5244A and N5245A Option 219
Installation to be performed by . . . . .	Agilent service center or personnel qualified by Agilent
Estimated installation time . . . . .	5 hours
Estimated adjustment time . . . . .	0.5 hours
Estimated full instrument calibration time . . . .	4.5 hours

## Items Included in the Upgrade Kit

Check the contents of your kit against the following list. If any part is missing or damaged, contact Agilent Technologies. Refer to [“Getting Assistance from Agilent”](#) on page 3.

**Table 1 Contents of Upgrade Kit N5242-60108**

Ref Desig.	Description	Qty	Part Number
-	Installation note (this document)	1	N5245-90012
A10	26.5 GHz source (2) assembly	1	5087-7327
A12	Doubler assembly, port 3	2	5087-7318
A13	Doubler assembly, port 4		
A17	13.5 GHz (source 2) synthesizer board	1	N5230-60002
A28	Mixer brick (2)	1	5087-7323
A30	Test port 3 reference coupler	2	5086-7658
A31	Test port 4 reference coupler		
A34	Test port 3 coupler	2	5087-7724
A35	Test port 4 coupler		
A39	Test port 3 source attenuator	2	33325-60012
A40	Test port 4 source attenuator		
A43	Test port 3 bias tee (includes wire harness)	2	5087-7331
A44	Test port 4 bias tee (includes wire harness)		
A47	Test port 3 receiver attenuator	2	33325-60011
A48	Test port 4 receiver attenuator		
A26	Splitter	1	5086-7408
-	Front frame, diecast, 4-port	1	N5245-20128
-	Machine screw, M2.0 x 6, flat head (to attach 2 reference couplers to brackets)	8	0515-1602
-	Machine screw, M3.0 x 25, pan head (to attach mixer brick A28 to mounting block)	3	0515-0667
-	Machine screw, M4.0 x 10, pan head (2 to attach source 2 to chassis; 2 to attach A12 doubler 3 to chassis; 2 to attach A13 doubler 4 to chassis)	6	0515-0380
-	Machine screw, M3.0 x 8, pan head (3 to attach shield to mixer brick; 8 to attach 2 src attn and 2 rcvr attn to brackets; 4 to attach 2 bias tee brackets to chassis; 1 to attach cable bracket to deck)	16	0515-0372
-	Machine screw, M2.5 x 16, pan head (to attach splitter to mixer brick)	2	0515-2007
-	Machine screw, M3.0 x 6, pan head (4 to attach 2 reference coupler/bracket assemblies to deck; 4 to attach 2 receiver attenuator/bracket assy. to deck; 4 to attach 2 source attenuator/bracket assy to deck)	12	0515-0430
-	Machine screw, M3.0 x 14, pan head (to attach 2 bias tees to brackets)	4	0515-0665
-	Front panel overlay (label), 4-port	1	N5242-80003
-	Nameplate	1	N5245-80003
-	Test set front plate, 4-port	1	N5245-00013

**Table 1 Contents of Upgrade Kit N5242-60108**

<b>Ref Desig.</b>	<b>Description</b>	<b>Qty</b>	<b>Part Number</b>
-	Gap pad (between each coupler and test set front sub panel)	4	E4403-20033
-	Gap pad (between mixer brick A28 and shield)	4	N5245-20125
-	Power button overlay (label)	1	N5242-80007
-	Keypad overlay (label)	1	N5242-80005
-	Shield, mixer brick	1	N5245-00023
-	3 dB pad, attached to R4 connector on A28 mixer brick	1	08490-60010
-	50 ohm load, attached to W58 (N5245-20095)	1	1810-0118
-	Vibration mount (between couplers 1 & 3, and 2 & 4)	2	0460-2725
-	Mounting nuts (for port 3 & 4 test port couplers)	2	5022-1087
-	Cable guard, center jumper cables	1	N5242-00030
-	Cable tie wrap, 1 to secure W21 (N5245-20008) to side of deck	1	1400-0249
-	Cable clamp, 1 to secure W25 (N5245-20116) to deck	1	1400-1334
-	Bracket for bias tee	2	N5245-00011
-	Bracket for reference coupler	2	N5245-00017
-	Bracket for cables	1	N5245-00022
-	Bracket for receiver attenuator; bracket for source attenuator	4	N5245-00015
W2	A10 (source 2) P1 to A17 13.5 GHz source (2) synthesizer J1207	1	N5245-20100
W7	A10 (source 2) P5 to A12 port 3 doubler	1	N5245-20034
W8	A10 (source 2) P3 to A13 port 4 doubler	1	N5245-20035
W9	A10 (source 2) P4 to A12 port 3 doubler	1	N5245-20032
W10	A12 port 3 doubler to A13 port 4 doubler	1	N5245-20033
W13	A12 port 3 doubler to W14	1	N5245-20036
W14	A30 port 3 reference coupler to W13	1	N5245-20043
W15	A13 port 4 doubler to W16	1	N5245-20036
W16	A31 port 4 reference coupler to W15	1	N5245-20044
W21	A29 port 1 reference coupler to A37 reference mixer switch	1	N5245-20008
W22	A33 port 1 coupler to front-panel Port 1 CPLR ARM	1	N5245-20014
W25	A30 port 3 ref coupler to front-panel REF 3 SOURCE OUT	1	N5245-20116
W26	A34 port 3 coupler to front-panel Port 3 CPLR ARM	1	N5245-20015
W29	A31 port 4 ref coupler to front-panel REF 4 SOURCE OUT	1	N5245-20117
W30	A35 port 4 coupler to front-panel Port 4 CPLR ARM	1	N5245-20018
W34	A36 port 2 coupler to front-panel Port 2 CPLR ARM	1	N5245-20019
W36	Front panel jumper	6	N5245-20104
W44	REF 3 RCVR R3 IN to A28 mixer brick (R3)	1	N5245-20020
W45	REF 4 RCVR R4 IN to 3 dB pad on A28 mixer brick (R4)	1	N5245-20021
W46	REF 2 RCVR R2 IN to A27 mixer brick (R2)	1	N5245-20115
W52	A25 HMA26.5 to A26 splitter	1	N5245-20013



**Table 1 Contents of Upgrade Kit N5242-60108**

<b>Ref Desig.</b>	<b>Description</b>	<b>Qty</b>	<b>Part Number</b>
W53	A26 splitter to A27 mixer brick	1	N5245-20023
W54	A26 splitter to A28 mixer brick	1	N5245-20022
W58	A28 mixer brick to 50 ohm load (1810-0118)	1	N5245-20095
W62	A27 mixer brick (R1) to A24 IF multiplexer (P411)	1	N5242-60021
W63	A27 mixer brick (R2) to A24 IF multiplexer (P412)	1	N5242-60022
W65	A28 mixer brick (D) to A24 IF multiplexer (P801)	1	N5242-60024
W66	A28 mixer brick (R4) to A24 IF multiplexer (P414)	1	N5242-60019
W67	A28 mixer brick (R3) to A24 IF multiplexer (P413)	1	N5242-60020
W68	A28 mixer brick (C) to A24 IF multiplexer (P601)	1	N5242-60023
W77	A14 frequency reference (J7) to A17 13.5 GHz (source 2) synth (J5)	1	N5242-60030
W83	A42 port 1 bias tee to front panel port 1 CPLR THRU	1	N5245-20085
W85	A30 port 3 reference coupler to A39 port 3 source attenuator	1	N5245-20026
W86	A39 port 3 source attenuator to front-panel Port 3 SOURCE OUT	1	N5245-20027
W87	Port 3 CPLR THRU to A43 port 3 bias tee	1	N5245-20089
W88	A43 port 3 bias tee to A34 port 3 coupler	1	N5245-20086
W89	A31 port 4 reference coupler to A40 port 4 source attenuator	1	N5245-20026
W90	A40 port 4 source attenuator to front-panel Port 4 SOURCE OUT	1	N5245-20028
W91	Port 4 CPLR THRU to A44 port 4 bias tee	1	N5245-20090
W92	A44 port 4 bias tee to A35 port 4 coupler	1	N5245-20088
W95	A45 port 2 bias tee to front panel port 2 CPLR THRU	1	N5245-20087
W99	Port 3 RCVR C IN to A47 port 3 receiver attenuator	1	N5245-20073
W100	A47 port 3 receiver attenuator to A28 mixer brick (C)	1	N5245-20066
W101	Port 4 RCVR D IN to A48 port 4 receiver attenuator	1	N5245-20074
W102	A48 port 4 receiver attenuator to A28 mixer brick (D)	1	N5245-20075
-	Ribbon cable, A23 test set motherboard J547 to A39 port 3 source attenuator	2	N5245-60006
-	Ribbon cable, A23 test set motherboard J548 to A40 port 4 source attenuator		
-	Ribbon cable, A23 test set motherboard J206 to A47 port 3 receiver attenuator	2	N5242-60007
-	Ribbon cable, A23 test set motherboard J207 to A48 port 4 receiver attenuator		
-	Ribbon cable, A23 test set motherboard J552 to A28 mixer brick (2) J52	1	N5245-60008

---

## Installation Procedure for the Upgrade

The network analyzer must be in proper working condition prior to installing this option. Any necessary repairs must be made before proceeding with this installation.

---

**WARNING**      **This installation requires the removal of the analyzer's protective outer covers. The analyzer must be powered down and disconnected from the mains supply before performing this procedure.**

---

### Overview of the Installation Procedure

- Step 1. Obtain a Keyword and Verify the Information.
- Step 2. Remove the Outer Cover.
- Step 3. Remove the Inner Cover.
- Step 4. Remove the Front Panel Assembly.
- Step 5. Remove the A23 Test Set Motherboard.
- Step 6. Remove Some Cables.
- Step 7. Remove the A27 Mixer Brick Assembly.
- Step 8. Assemble the A28 Mixer Brick Assembly.
- Step 9. Install the A27/A28 Mixer Bricks Assembly.
- Step 10. Assemble the A30 and A31 Reference Coupler Assemblies.
- Step 11. Install the A30 and A31 Reference Coupler Assemblies.
- Step 12. Assemble the A47 and A48 Receiver Attenuator Assemblies.
- Step 13. Install the A47 and A48 Receiver Attenuator Assemblies.
- Step 14. Assemble the A39 and A40 Source Attenuator Assemblies.
- Step 15. Install the A39 and A40 Source Attenuator Assemblies.
- Step 16. Install the Bias Tee Brackets.
- Step 17. Install the A43 and A44 Bias Tees.
- Step 18. Assemble the A33 - A36 Test Port Coupler Assemblies.
- Step 19. Install the LED Boards and Test Port Coupler Assemblies to the Test Set Front Plate.
- Step 20. Install the Coupler Plate Assembly to the Deck.
- Step 21. Assemble the A10 26.5 GHz Source 2 Assembly.
- Step 22. Assemble and Install the A12 and A13 Doubler Assemblies.
- Step 23. Install the A10 26.5 GHz Source 2 Assembly and Cables.
- Step 24. Install the A17 13.5 GHz (Source 2) Synthesizer Board and Cables.
- Step 25. Install the Test Set Cables.

- Step 26. Secure the Front Panel Bulkhead Connectors.
- Step 27. Reinstall the A23 Test Set Motherboard.
- Step 28. Replace the Front Frame in the Front Panel Assembly.
- Step 29. Reinstall Front Panel Assembly.
- Step 30. Install the Overlays.
- Step 31. Install the Front Panel Jumper Cables.
- Step 32. Reinstall the Inner Cover.
- Step 33. Reinstall the Outer Cover.
- Step 34. Install the Cable Guard.
- Step 35. Enable Options P04 (400) and 419.
- Step 36. Perform Post-Upgrade Adjustments and Calibration.

## **Step 1. Obtain a Keyword and Verify the Information**

Follow the instructions on the Option Entitlement Certificate supplied to obtain a license key for installation of this upgrade. Refer to [“License Key Redemption” on page 4](#).

Verify that the model number, serial number, and option number information on the license key match those of the instrument on which this upgrade will be installed.

If the model number, serial number, or option number do not match those on your license key, you will not be able to install the option. If this is the case, contact Agilent for assistance before beginning the installation of this upgrade. Refer to [“Contacting Agilent” on page 3](#).

Once the license key has been received and the information verified, you can proceed with the installation at step 2.

## **Step 2. Remove the Outer Cover**

For instructions, click the Chapter 7 bookmark “Removing the Covers” in the PDF Service Guide<sup>1</sup>.

## **Step 3. Remove the Inner Cover**

For instructions, click the Chapter 7 bookmark “Removing the Covers” in the PDF Service Guide<sup>1</sup>.

## **Step 4. Remove the Front Panel Assembly**

For instructions, click the Chapter 7 bookmark “Removing and Replacing the Front Panel Assembly” in the PDF Service Guide<sup>1</sup>.

---

1. See [“Downloading the Online PNA Service Guide” on page 5](#).

## Step 5. Remove the A23 Test Set Motherboard

For instructions, click the Chapter 7 bookmark “Removing and Replacing the A23 test set motherboard” in the PDF Service Guide<sup>1</sup>.

## Step 6. Remove Some Cables

---

**CAUTION** Be careful not to damage the center pins of the semirigid cables. Some flexing of the cables may be necessary but do not over-bend them.

---

1. Place the analyzer bottom-side up on a flat surface.
2. Remove all bottom-side (test set) semirigid cables except for those in the following table. Do not discard the cables that are removed because some will be reused later in the procedure.

To see an image showing the location of cables W11, W17, and W51 click the Chapter 6 bookmark “Top Cables, All Cables - All Options” in the PDF Service Guide<sup>1</sup>. To see an image showing the location of cables W55, W56, and W57, click the Chapter 6 bookmark “Bottom RF Cables, 2-Port, Option 219” in the PDF Service Guide<sup>1</sup>.

Reference Designator	Type <sup>a</sup>	Part Number	Qty	Description
W11	SR	N5245-20036	1	A7 port 1 doubler to W12
W17	SR	N5245-20036	1	A8 port 2 doubler to W18
W51	SR	N5245-20101	1	A15 13.5 GHz (LO) synthesizer board J1207 to A25 HMA26.5
W55	SR	N5245-20102	1	A7 port 1 doubler to W56
W56	SR	N5245-20103	1	W55 to rear-panel EXT TSET DRIVE RF OUT (J6)
W57	SR	N5245-20012	1	A27 mixer brick to EXT TSET DRIVE LO OUT (J5)

a. SR = semirigid coaxial cable.

3. Remove and discard the following gray flexible cables:
  - W62 (N5242-60025) A27 mixer brick (R1) to A24 IF multiplexer (P601)
  - W63 (N5242-60026) A27 mixer brick (R2) to A24 IF multiplexer (P801)
4. Leave the remaining gray flexible cables, the wire harnesses, and the ribbon cables connected where possible. Any that are removed should be labeled for reconnection later.

## Step 7. Remove the A27 Mixer Brick Assembly

Remove the A27 mixer brick assembly from the PNA. For instructions, click the Chapter 7 bookmark, “Removing and Replacing the A27 and A28 Mixer Bricks” in the PDF Service Guide<sup>1</sup>.

---

1. See “[Downloading the Online PNA Service Guide](#)” on page 5.

## Step 8. Assemble the A28 Mixer Brick Assembly

1. Follow the two instructions shown in [Figure 1](#). New parts are listed in [Table 1 on page 7](#) of this document.

**Figure 1 A28 Mixer Brick Assembly**



① Install A28 mixer brick 5087-7323. Secure with screws 0515-0667. Torque to 9 in-lbs.

② Add Gap pads N5245-20125 X4 to mixer brick as shown.

Not necessary to remove A27 mixer brick shield as shown.

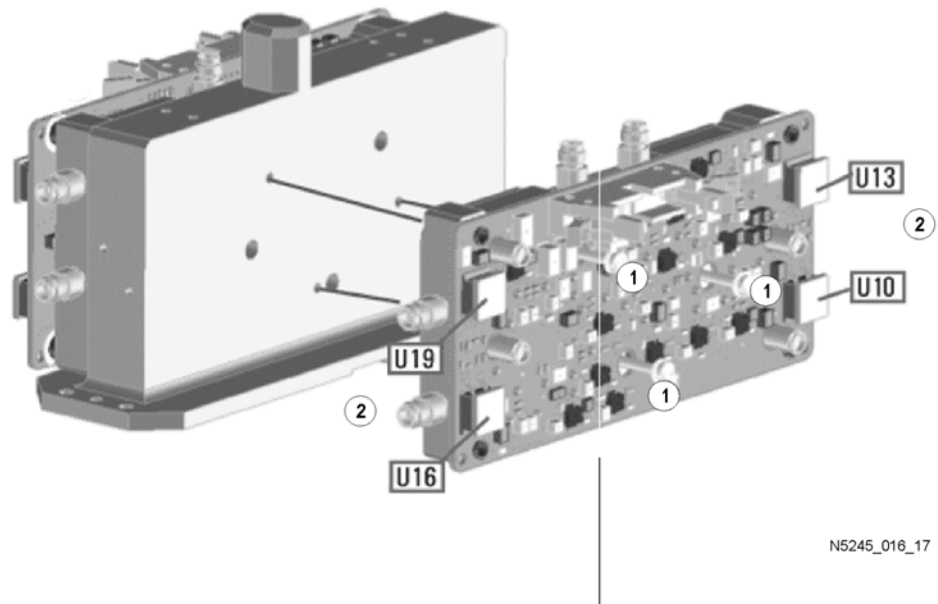

2. Follow the four instructions shown in [Figure 2](#).

**Figure 2 Shields, Splitter, and 3 dB Pad Installation**



① Add shield N5245-00023 X1 as shown over A28 mixer brick.

② Secure with Screws 0515-0372 X3. Torque to 9 in-lbs.

③ Install Splitter 5086-7408, secure with screws 0515-2007 X2. Leave Loose for now. ( Label P/N Up)

④ Install 3dB pad 08490-60010 X1 only on R4 connector of A28 mixer brick. Torque to 10 in-lbs.

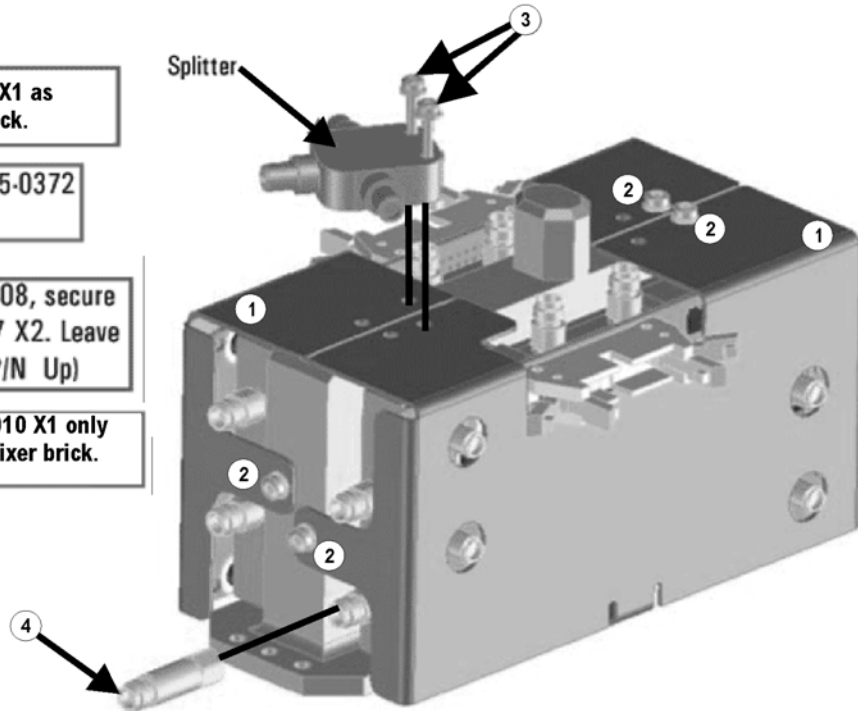

N5245\_016\_18

3. Connect the gray flexible cables in the order shown in [Figure 3](#).

---

**NOTE** Graphics in this document such as [Figure 3](#) use very brief text to instruct where to connect a cable. For example, text that reads “N5242-60018 IFMUX P201 - BRK1 B” means to connect the N5242-60018 gray flexible cable at the A24 IF MUX board connector P201 and at A27 Mixer Brick 1 connector B.

---

**Figure 3 A28 Mixer Brick Cable Installation**

-  Agilent Technologies
- ① Install Cable N5242-60024, IFMUX P801-BRK2 D.
  - ② Install Cable N5242-60019, IFMUX P414-BRK2 R4.
  - ③ Install Cable N5242-60020, IFMUX P413-BRK2 R3.
  - ④ Install Cable N5242-60023, IFMUX P601-BRK2 C.
  - ⑤ Torque SMA nuts to 10 in-lbs. Note: Orientation of Gray Cable SMA connector on mixer brick.

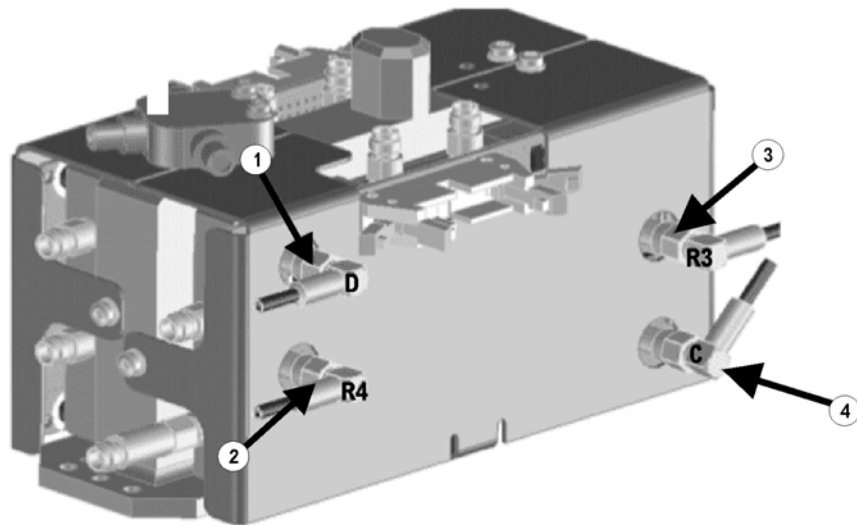

N5245\_016\_19

## Step 9. Install the A27/A28 Mixer Bricks Assembly

Install the A27/A28 mixer brick assembly, reusing the 4 existing screws. For instructions, click the Chapter 7 bookmark, “Removing and Replacing the A27 and A28 Mixer Bricks” in the PDF Service Guide<sup>1</sup>. New parts are listed in [Table 1 on page 7](#) of this document

## Step 10. Assemble the A30 and A31 Reference Coupler Assemblies

Follow the instruction shown in [Figure 4](#). New parts are listed in [Table 1 on page 7](#) of this document.

**Figure 4** A30 and A31 Reference Coupler Assembly

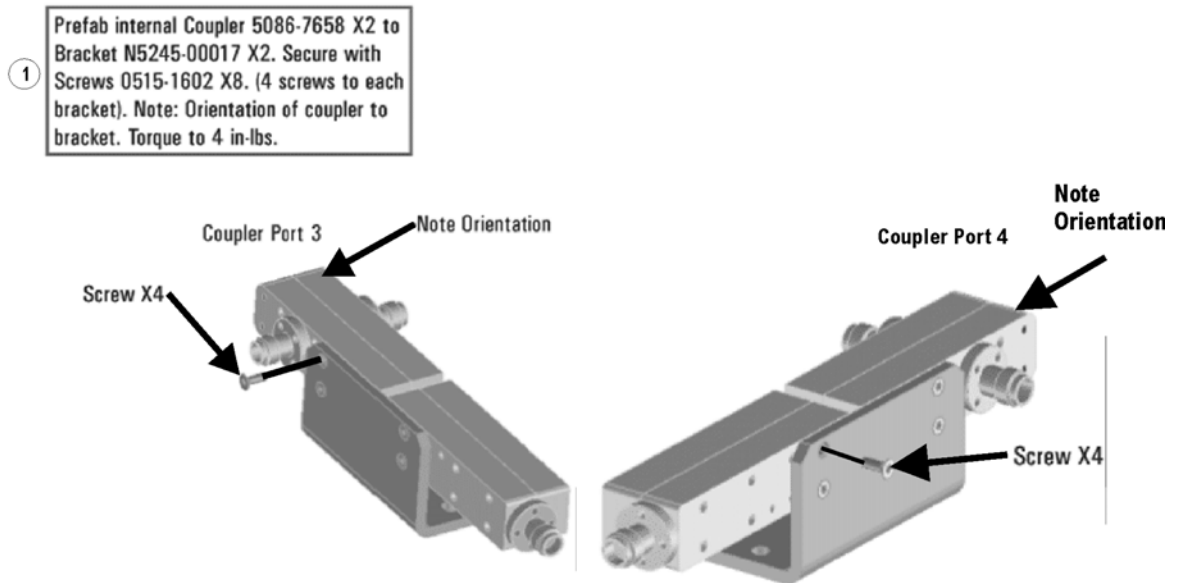

N5245\_016\_20

1. See “[Downloading the Online PNA Service Guide](#)” on page 5.



### **Step 11. Install the A30 and A31 Reference Coupler Assemblies**

Install the A30 and A31 reference coupler assemblies. For instructions, click the Chapter 7 bookmark, “Removing and Replacing the A29-A32 Reference Couplers and Reference Coupler Mounting Brackets” in the PDF Service Guide<sup>1</sup>. New parts are listed in [Table 1 on page 7](#) of this document.

### **Step 12. Assemble the A47 and A48 Receiver Attenuator Assemblies**

Assemble the A47 and A48 receiver attenuator assemblies. For instructions, click the Chapter 7 bookmark, “Removing and Replacing the A38-A41 Source Attenuators and the A46-A49 Receiver Attenuators” in the PDF Service Guide<sup>1</sup>. New parts are listed in [Table 1 on page 7](#) of this document.

### **Step 13. Install the A47 and A48 Receiver Attenuator Assemblies**

Install the A47 and A48 receiver attenuator assemblies. For instructions, click the Chapter 7 bookmark, “Removing and Replacing the A38-A41 Source Attenuators and the A46-A49 Receiver Attenuators” in the PDF Service Guide<sup>1</sup>. New parts are listed in [Table 1 on page 7](#) of this document.

### **Step 14. Assemble the A39 and A40 Source Attenuator Assemblies**

Assemble the A39 and A40 source attenuator assemblies. For instructions, click the Chapter 7 bookmark, “Removing and Replacing the A38-A41 Source Attenuators and the A46-A49 Receiver Attenuators” in the PDF Service Guide<sup>1</sup>. New parts are listed in [Table 1 on page 7](#) of this document.

### **Step 15. Install the A39 and A40 Source Attenuator Assemblies**

Install the A39 and A40 source attenuator assemblies. For instructions, click the Chapter 7 bookmark, “Removing and Replacing the A38-A41 Source Attenuators and the A46-A49 Receiver Attenuators” in the PDF Service Guide<sup>1</sup>.

---

1. See [“Downloading the Online PNA Service Guide” on page 5](#).

## Step 16. Install the Bias Tee Brackets

Refer to [Figure 5](#) for this step of the procedure. New parts are listed in [Table 1 on page 7](#).

**Figure 5** Bias Tee Brackets

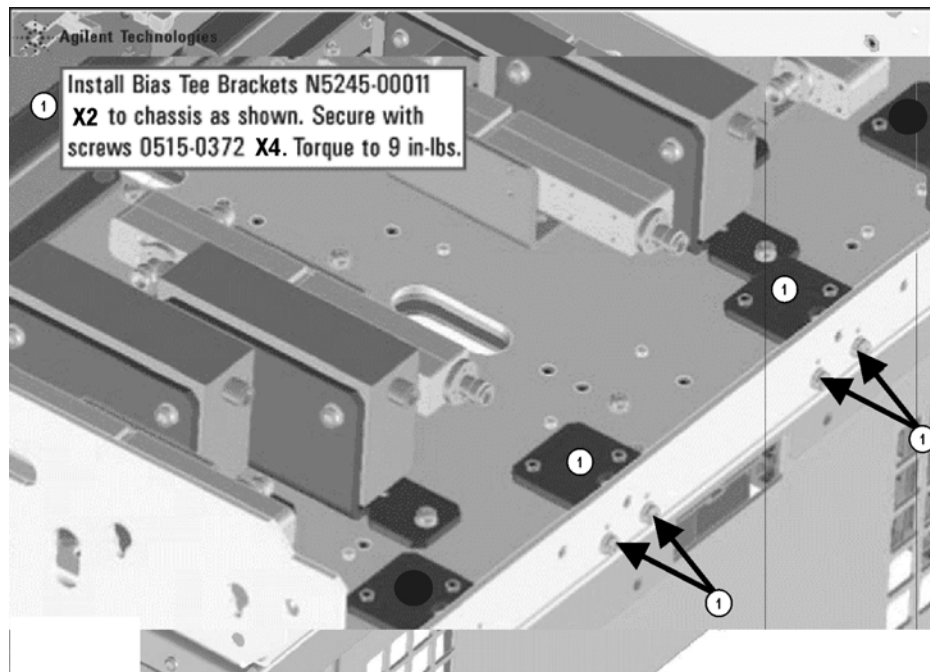

N5245\_016\_21

## Step 17. Install the A43 and A44 Bias Tees

Install the A43 and A44 bias tees. For instructions, click the Chapter 7 bookmark, “Removing and Replacing the A42-A45 Bias Tees” in the PDF Service Guide<sup>1</sup>. New parts are listed in [Table 1 on page 7](#) of this document.

---

**NOTE** Orient the port 3 bias tee so that the capacitor faces the capacitor on the port 1 bias tee. Likewise, port 2 and port 4 bias tee capacitors should face each other. Also, fasten each bias tee’s red wire lug nut using the screw on the side of the bias tee without a capacitor.

---

1. See [“Downloading the Online PNA Service Guide” on page 5](#).

## Step 18. Assemble the A33 - A36 Test Port Coupler Assemblies

1. Remove the A33 test port 1 coupler and A36 test port 2 coupler from the PNA. For instructions, click the Chapter 7 bookmark, “Removing and Replacing the A33 - A36 Test Port Couplers” in the PDF Service Guide<sup>1</sup>.
2. Using pliers, remove the adhesive bumper on the A33 test port 1 coupler and on the A36 test port 2 coupler.
3. Follow the two instructions shown in [Figure 6](#). New parts are listed in [Table 1 on page 7](#) of this document.

**Figure 6 A33 - A36 Test Port Coupler Assembly**

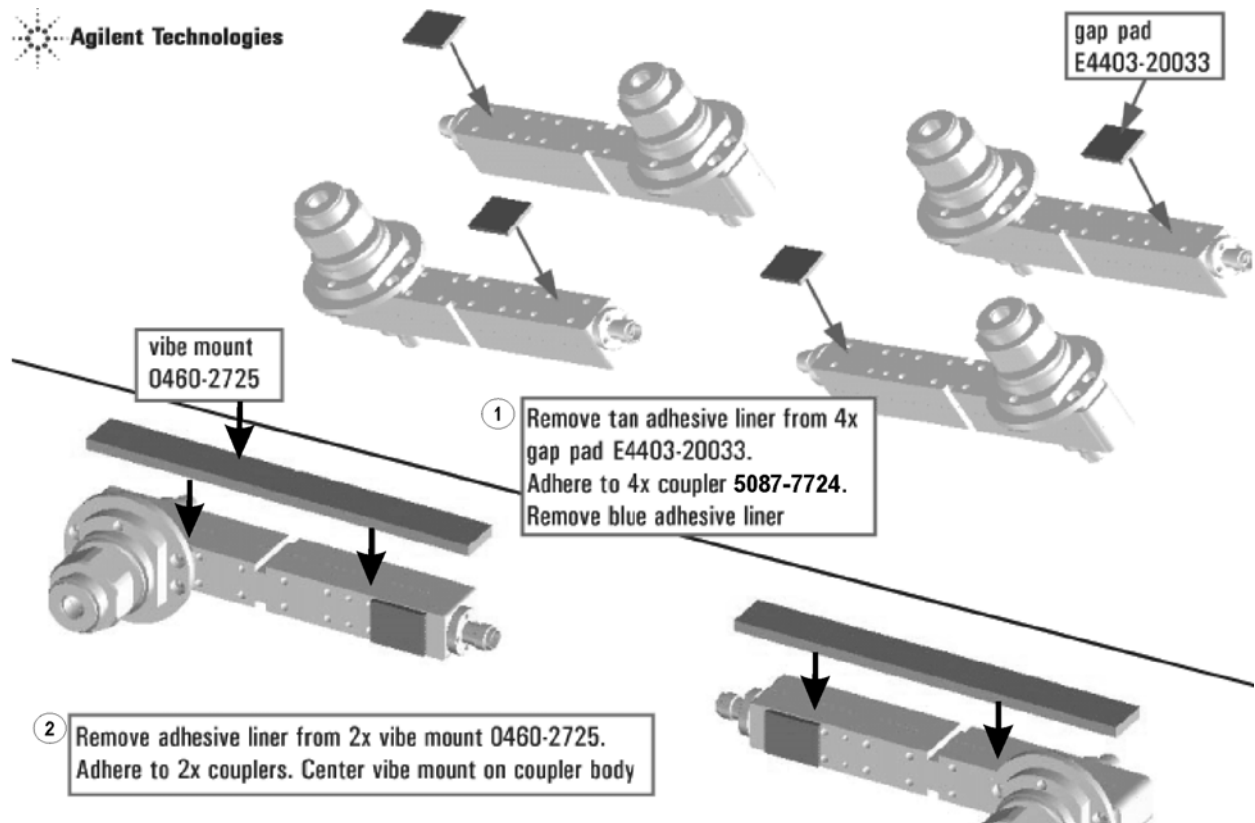

1. See “[Downloading the Online PNA Service Guide](#)” on page 5.

## Step 19. Install the LED Boards and Test Port Coupler Assemblies to the Test Set Front Plate

1. Remove two screws from each LED board and remove the boards from the 2-port test set front plate of the PNA.
2. Remove the 2-port test set front plate from the test set deck.
3. Follow the two instructions shown in [Figure 7](#).

**Figure 7 LED Board Assemblies and Test Port Coupler Assemblies Installation**

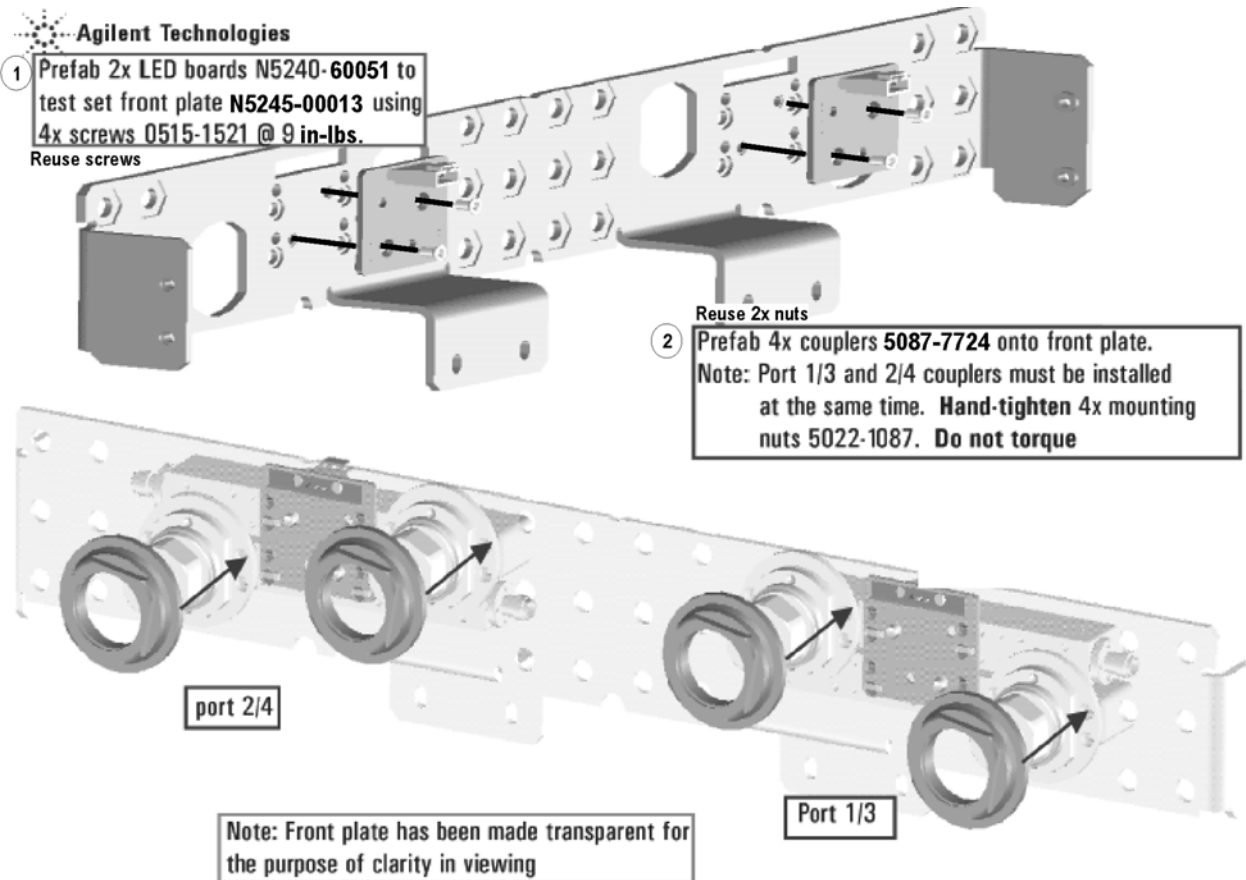

N5245\_016\_12

## Step 20. Install the Coupler Plate Assembly to the Deck

Follow the four instructions shown in Figure 8.

Figure 8 Coupler Plate Assembly Installation



Agilent Technologies

Reuse screws  
① Install coupler plate assy to deck. Hand-tighten 4x screws 0515-0372. Do not torque.

Reuse screws  
② Install 4x screws 0515-1227 @ 9 in-lbs. Alternate sides in torque sequence.

③ Torque the 4x screws in step 1 to 9 in-lbs.

④ Torque 4x coupler mounting nuts to 72 in-lbs.

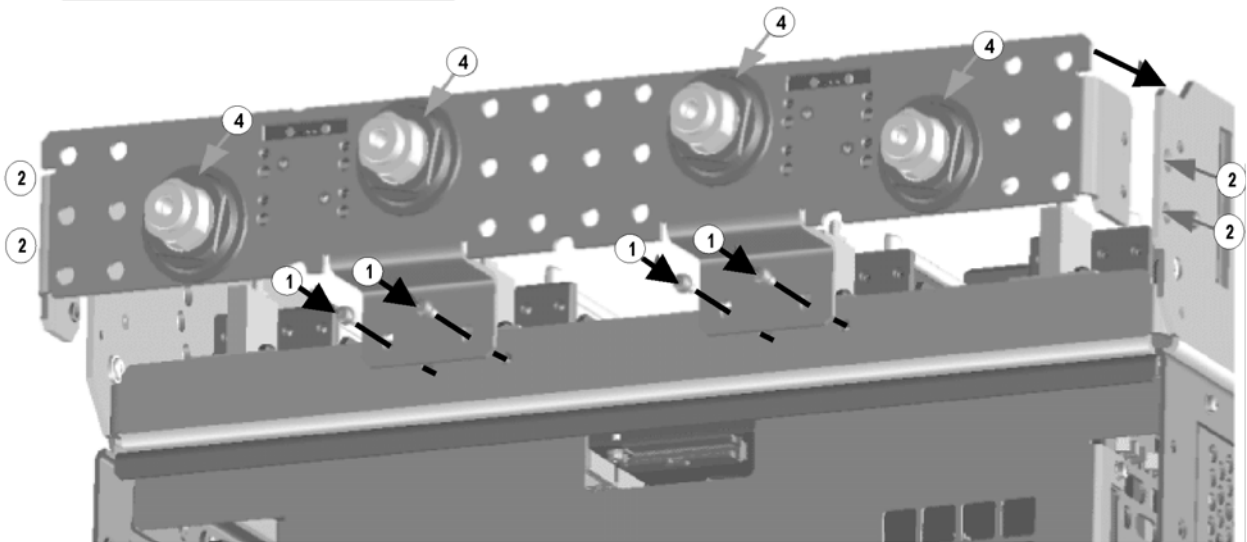

N5245\_016\_13

## Step 21. Assemble the A10 26.5 GHz Source 2 Assembly

Follow the four instructions shown in [Figure 9](#).

**Figure 9** A10 Source 2 Assembly

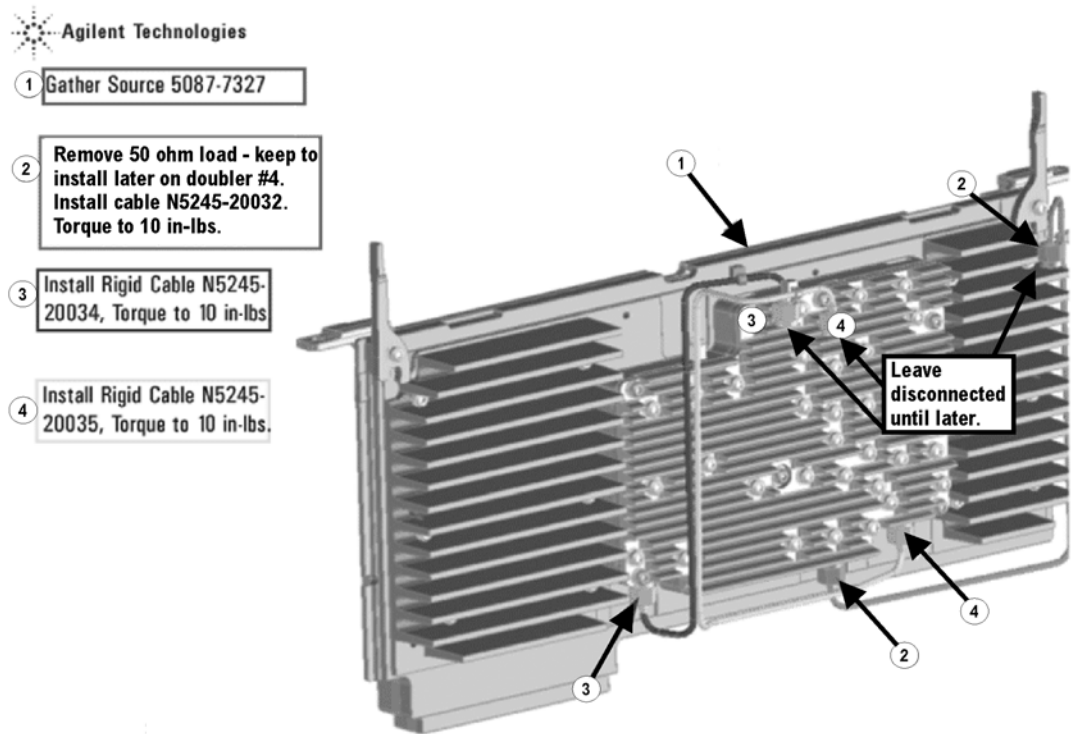

N5245\_015\_38

## Step 22. Assemble and Install the A12 and A13 Doubler Assemblies

Follow the four instructions shown in [Figure 10](#).

**Figure 10** A12 and A13 Doubler Assemblies Installation

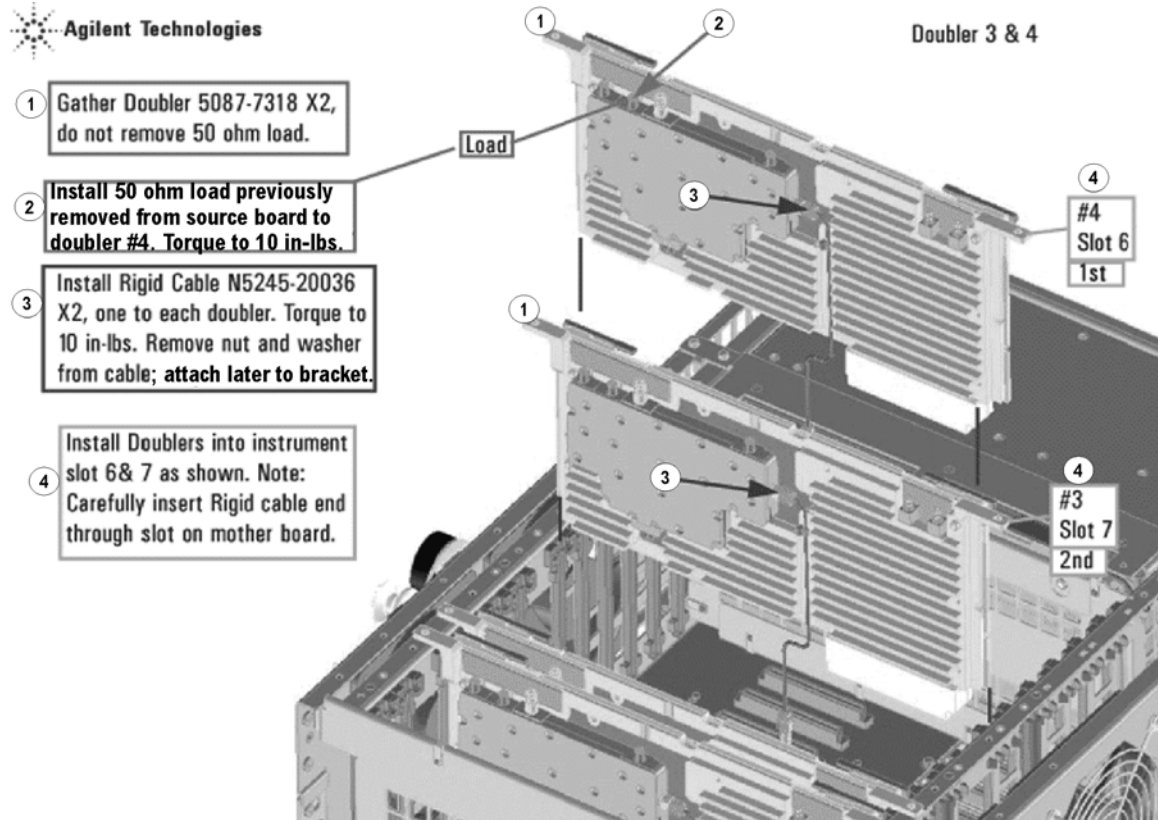

N5245\_016\_37



## Step 23. Install the A10 26.5 GHz Source 2 Assembly and Cables

Follow the four instructions shown in [Figure 11](#).

**Figure 11** A10 Source 2 Assembly Installation

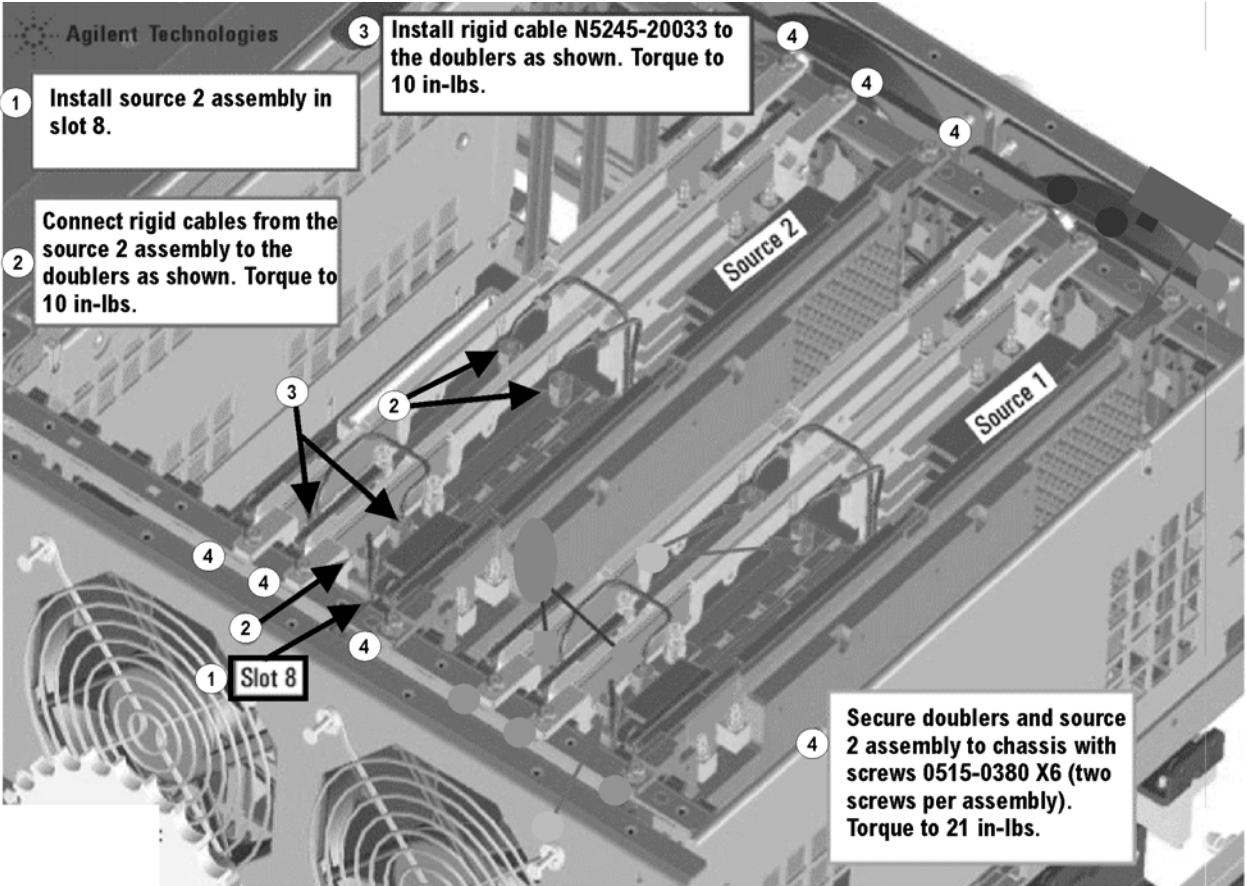

N5245\_015\_39



## Step 24. Install the A17 13.5 GHz (Source 2) Synthesizer Board and Cables

1. Install gray cable W67 (N5242-60030) to connector J5 of the A17 (source 2) synthesizer board (N5230-60002). The loose end of the cable will be connected on the A14 frequency reference board (J7) after the A17 board has been installed in the analyzer.
2. Install the A17 board into slot 2 in the motherboard. To see an image showing the location of the A17 board in the motherboard, click the Chapter 6 bookmark “Top Assemblies, All Options” in the PDF Service Guide<sup>1</sup>.
3. Connect cable W2 (N5245-20100) between the A10 source 2 board and the A17 (source 2) synthesizer board, positioning the cable in the wire looms. Tighten the cable connectors to 10 in-lbs using a 5/16-in torque wrench.
4. Connect the loose end of new gray flex cable W22 (N5242-60030) on the A14 frequency reference board (J7). (The other end of this cable was previously connected to J5 of the source 2 synthesizer board.)

## Step 25. Install the Test Set Cables

---

**CAUTION** Use a 5/16-in torque wrench set to 10 in-lbs on all cable connections except the front and rear panel cable connectors. Torque these connections to 21 in-lb.

---

### Flexible Cables Required for Upgrading to an Option 419 PNA

Install the following flexible cables in the order listed. To see images showing the location of these cables, click either of the Chapter 6 bookmarks “Bottom RF Cables, 4-Port, Option 419” in the PDF Service Guide<sup>1</sup>. New parts are listed in [Table 1 on page 7](#).

- W62 (N5242-60021) A27 mixer brick (R1) to A24 IF multiplexer (P411)
- W63 (N5242-60022) A27 mixer brick (R2) to A24 IF multiplexer (P412)

---

1. See “[Downloading the Online PNA Service Guide](#)” on page 5.

## Semirigid Cables Required for Upgrading to an Option 419 PNA

To see images showing the location of these cables, click the Chapter 6 bookmark “Bottom RF Cables, 4-Port, Option 419” in the PDF Service Guide<sup>1</sup>. New parts are listed in [Table 1 on page 7](#).

- Follow the two instructions shown in [Figure 12](#) in this document.

**Figure 12 Semirigid Cables Installation**

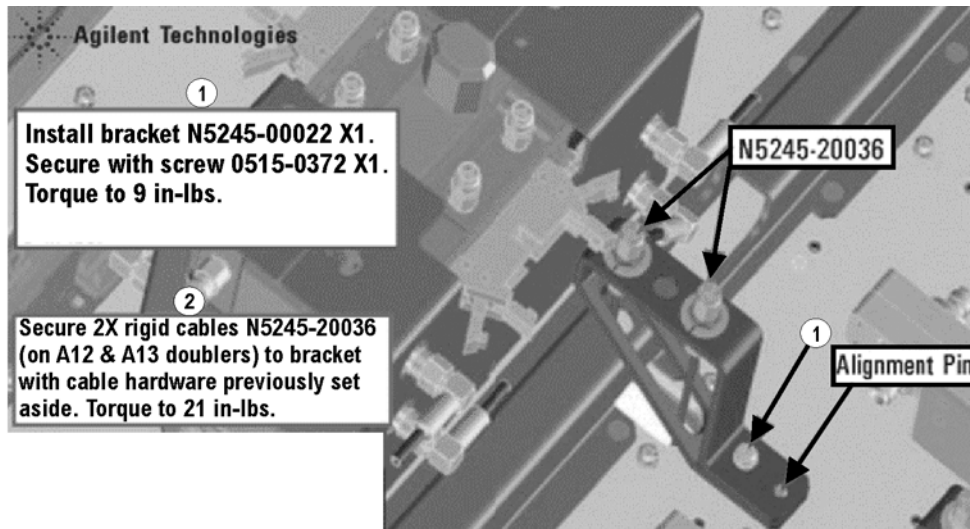

N5245\_016\_32

- W95 (N5245-20087) A45 port 2 bias tee to port 2 CPLR THRU
- W92 (N5245-20088) A44 port 4 bias tee to A35 port 4 coupler
- W83 (N5245-20085) A42 port 1 bias tee to A33 port 1 coupler
- W88 (N5245-20086) A43 port 3 bias tee to A34 port 3 coupler

1. See “[Downloading the Online PNA Service Guide](#)” on page 5.

- W25 (N5245-20116) A30 port 3 ref coupler to front-panel REF 3 SOURCE OUT  
\* As shown in [Figure 13](#), install clamp part number 1400-1334 to secure W25.

**Figure 13 Location of Cable Clamp to Secure W25 (N5245-20116)**

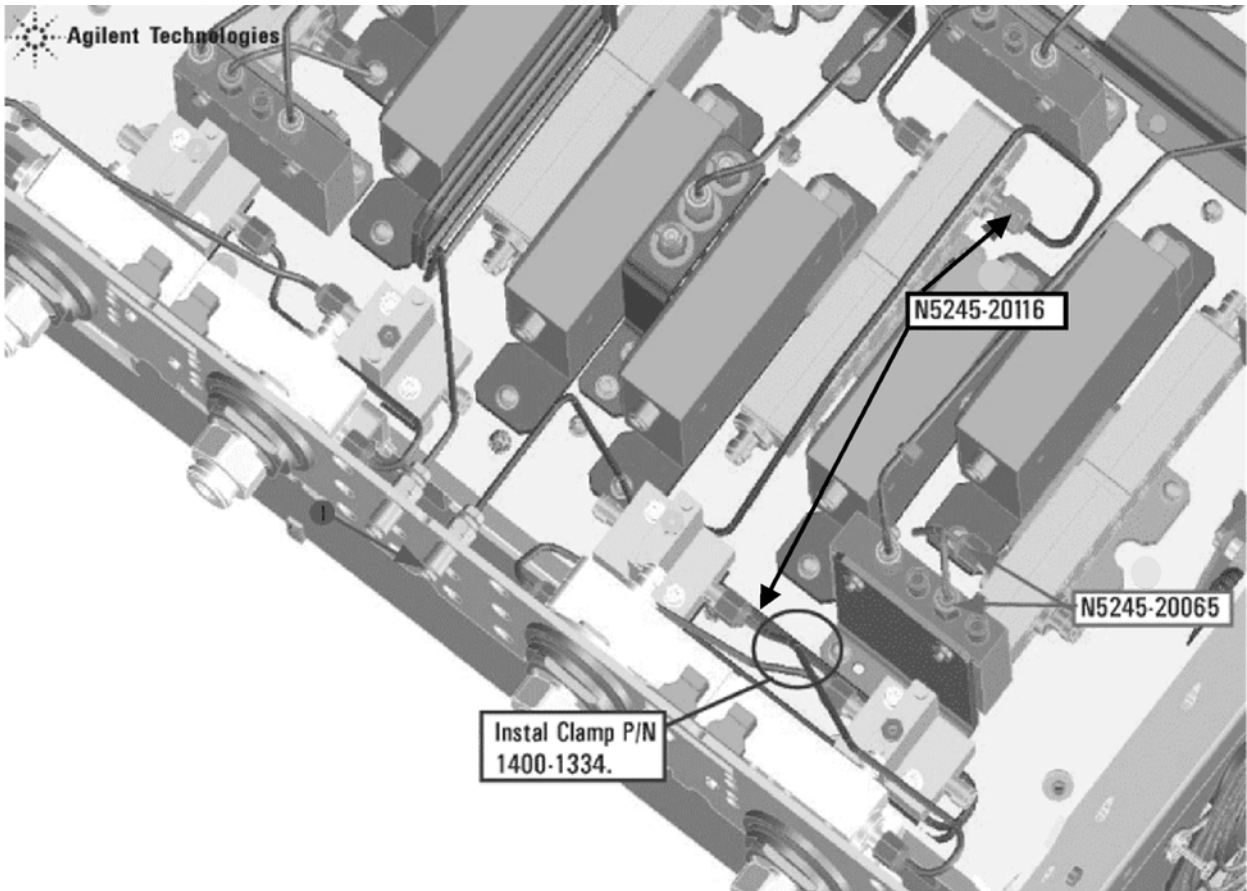

N5245\_010\_02

- W29 (N5245-20117) A31 port 4 ref coupler to front-panel REF 4 SOURCE OUT
- W89 (N5245-20026) A31 port 4 reference coupler to A40 port 4 source attenuator
- W85 (N5245-20026) A30 port 3 reference coupler to A39 port 3 source attenuator
- W93(reuse) (N5245-20029) A32 port 2 reference coupler to A41 port 2 source attenuator
- W81(reuse) (N5245-20029) A29 port 1 reference coupler to A38 port 1 source attenuator
- W103(reuse) (N5245-20055) Port 2 RCVR B IN to A49 port 2 receiver attenuator
- W96(reuse) (N5245-20030) Port 2 CPLR THRU to A45 port 2 bias tee
- W34 (N5245-20019) A36 port 2 coupler to front-panel Port 2 CPLR ARM
- W94(reuse) (N5245-20031) A41 port 2 source attenuator to front-panel Port 2 SOURCE OUT
- W46 (N5245-20115) REF 2 RCVR R2 IN to A27 mixer brick (R2)  
\* Connect W46 to top R2 connector on the mixer bricks.

- W33(reuse) (N5245-20010) A32 port 2 ref coupler to front-panel REF 2 SOURCE OUT
- W30 (5245-20018) A35 port 4 coupler to front-panel Port 4 CPLR ARM
- W101 (N5245-20074) Port 4 RCVR D IN to A48 port 4 receiver attenuator
- W90 (N5245-20028) A40 port 4 source attenuator to front-panel Port 4 SOURCE OUT
- W91 (N5245-20090) Port 4 CPLR THRU to A44 port 4 bias tee
- W45(N5245-20021)REF 4 RCVR R4 IN to A28 mixer brick (R4)  
\* Connect W45 to the 3 dB pad on the A28 mixer brick.
- W99 (N5245-20073) Port 3 RCVR C IN to A47 port 3 receiver attenuator
- W87 (N5245-20089) Port 3 CPLR THRU to A43 port 3 bias tee
- W26 (N5245-20015) A34 port 3 coupler to front-panel Port 3 CPLR AR
- W86 (N5245-20027) A39 port 3 source attenuator to front-panel Port 3 SOURCE OUT
- W44 (N5245-20020) REF 3 RCVR R3 IN to A28 mixer brick (R3)  
\* Connect W44 to top R3 connector on the mixer bricks.
- W22 (N5245-20014) A33 port 1 coupler to front-panel Port 1 CPLR ARM
- W97(reuse) (N5245-20054) Front-panel Port 1 RCVR A IN to A46 port 1 receiver attenuator
- W82(reuse) (N5245-20077) A38 port 1 source attenuator to front-panel Port 1 SOURCE OUT
- W84(reuse) N5245-20076) Front-panel Port 1 CPLR THRU to A42 port 1 bias tee
- W42(reuse) (N5245-20007) REF 1 RCVR R1 IN to A37 reference mixer switch

- W21 (N5245-20008) A29 port 1 reference coupler to A37 reference mixer switch  
\* As shown in [Figure 14](#), install cable tie part number 1400-0249 to secure W21.

**Figure 14 Location of Cable Tie to Secure W21 (N5245-20008)**

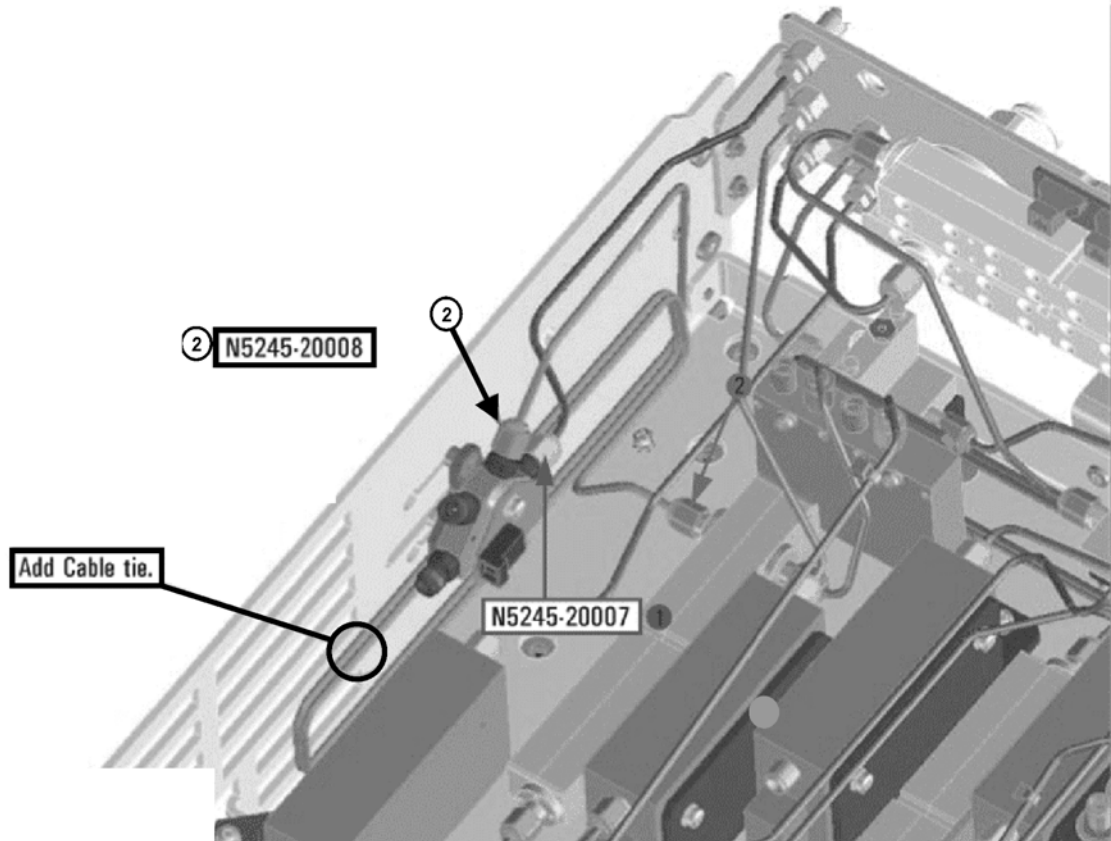

N5245\_010\_16

- W43(reuse) (N5245-20009) A37 reference mixer switch to A27 mixer brick (R1)  
\* Connect W43 to bottom R1 connector on the mixer bricks.
- W41(reuse) (N5245-20006) A37 reference mixer switch to front-panel REF 1 SOURCE OUT
- W102 (N5245-20075) A48 port 4 receiver attenuator to A28 mixer brick (D)  
\* Connect W102 to top D connector on the mixer bricks.
- W100 (N5245-20066) A47 port 3 receiver attenuator to A28 mixer brick (C)  
\* Connect W100 to bottom C connector on the mixer bricks.
- W104(reuse) (N5245-20057) A49 port 2 receiver attenuator to A27 mixer brick (B)  
\* Connect W104 to bottom B connector on the mixer bricks
- W98(reuse) N5245-20056) A46 port 1 receiver attenuator to A27 mixer brick (A)  
\* Connect W98 to top A connector on the mixer bricks.
- W18(reuse) (N5245-20049) A32 port 2 reference coupler to W17
- W12(reuse) (N5245-20050) A29 port 1 reference coupler to W11

- W16 (N5245-20044) A31 port 4 reference coupler to W15
- W14 (N5245-20043) A30 port 3 reference coupler to W13
- W54 (N5245-20022) A26 splitter to A27 mixer brick
- W53 (N5245-20023) A26 splitter to A27 mixer brick
- W52 (N5245-20013) A25 HMA26.5 to A26 splitter
- W58 (N5245-20095) A28 mixer brick to 50 ohm load (1810-0118)
  - \* After installing W58 to the mixer brick, attach the new 50 ohm load (1810-0118) using a 1/4 inch open end wrench to hold cable W58 in place.
  - \* Torque A26 splitter screws to 6 in-lbs.

## Step 26. Secure the Front Panel Bulkhead Connectors

Follow the instruction shown in [Figure 15](#) in this document.

**Figure 15 Bulkhead Connections, Front Panel**

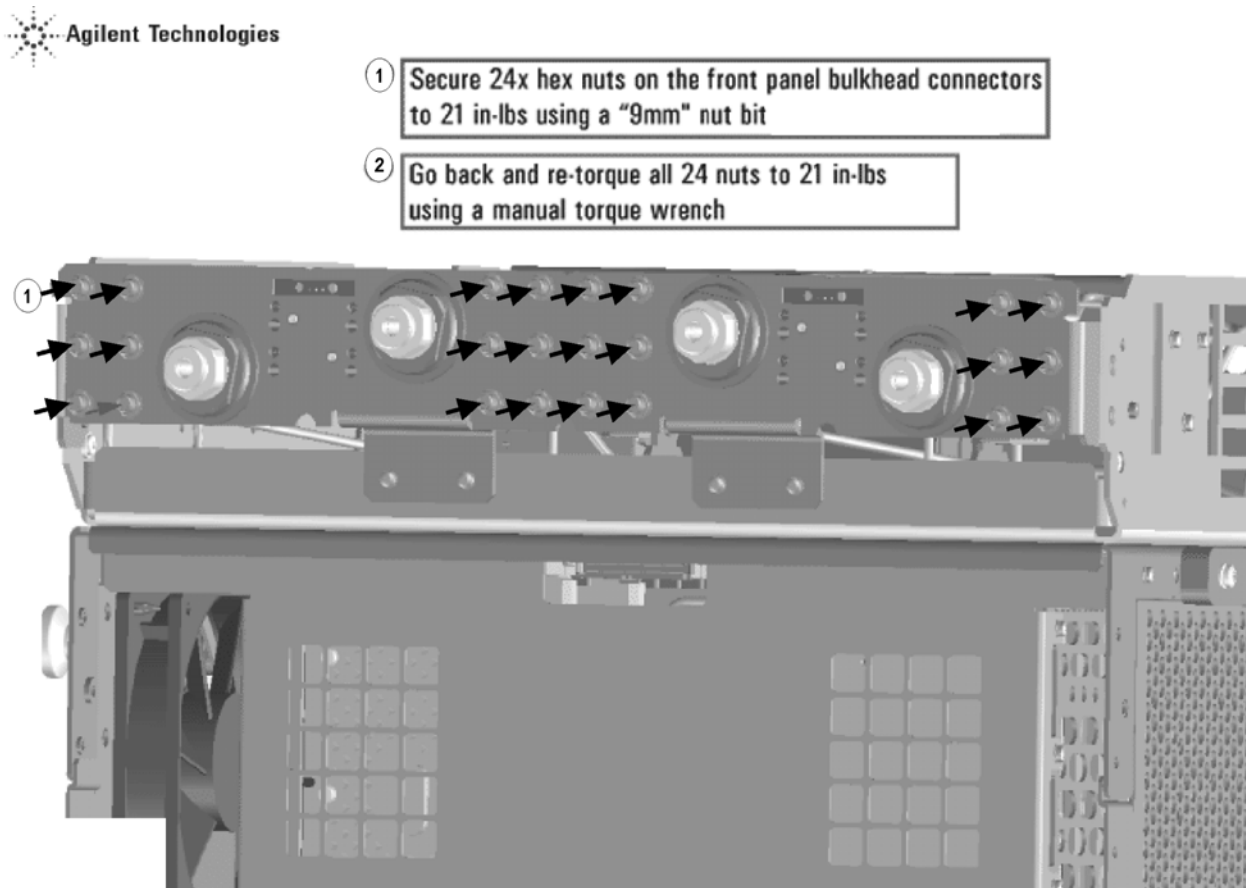

N5245\_016\_31



## Step 27. Reinstall the A23 Test Set Motherboard

1. For instructions on reinstalling the board, click the Chapter 7 bookmark “Removing and Replacing the A23 test set motherboard” in the PDF Service Guide<sup>1</sup>.
2. If not already done in a previous step, install the following new ribbon cables in the order listed. To see an image showing the location of these cables, click the Chapter 6 bookmark “Bottom Ribbon Cables and Wire Harnesses, 4-Port, Option 419” in the PDF Service Guide<sup>1</sup>. New parts are listed in [Table 1 on page 7](#).
  - Ribbon cable, N5245-60008 from A23 test set motherboard J552 to A28 mixer brick (2) J52
  - Ribbon cable (part of bias tee assembly), port 3 bias tee to A23 test set motherboard J543
  - Ribbon cable (part of bias tee assembly), port 4 bias tee to A23 test set motherboard J544
  - Ribbon cable (N5242-60007), A23 test set motherboard J206 to A47 port 3 receiver attenuator
  - Ribbon cable (N5242-60007), A23 test set motherboard J207 to A48 port 4 receiver attenuator
  - Ribbon cable (N5245-60006), A23 test set motherboard J547 to A39 port 3 source attenuator
  - Ribbon cable (N5245-60006), A23 test set motherboard J548 to A40 port 4 source attenuator

## Step 28. Replace the Front Frame in the Front Panel Assembly

Before the front frame can be replaced, the items making up the back side of the front panel assembly must be removed. For instructions on removing these items, click the Chapter 7 bookmark “Removing and Replacing the A1-A3 and Other Front Panel Subassemblies” in the PDF Service Guide<sup>1</sup>. New parts are listed in [Table 1 on page 7](#).

1. In the section “Removing the A2 USB Board,” perform the only step.
2. In the section “Removing the A1 Front Panel Interface Board and Keypad Assembly,” perform steps 1 - 5.
3. In the section “Removing the Power Switch Board and Power Button Keypad,” perform only steps 1 and 2.
4. Remove the braided gasket from the backside edges of the 2-port front frame and install it in the 4-port front frame (N5245-20128).
5. Reassemble the front panel assembly with the new 4-port front frame by reversing the order of the instructions previously followed.

---

1. See “[Downloading the Online PNA Service Guide](#)” on page 5.

## Step 29. Reinstall Front Panel Assembly

For instructions on reinstalling the front panel assembly, click the Chapter 7 bookmark “Removing and Replacing the Front Panel Assembly” in the PDF Service Guide<sup>1</sup>.

## Step 30. Install the Overlays

To see an image of the front panel overlay (N5242-80003), keypad overlay (N5242-80005), and power button overlay (N5242-80007), click the Chapter 6 bookmark “Front Panel Assembly, Front Side, All Options” in the PDF Service Guide<sup>1</sup>. New parts are listed in [Table 1 on page 7](#).

1. Remove the protective backing from the new front panel overlay (N5242-80003).
2. Loosely place the overlay in the recess on the lower front panel.
3. Placing two fingers at the middle, press the overlay firmly onto the frame while sliding your fingers in opposite directions towards the ends of the overlay. Repeat on all areas of the overlay.
4. Repeat steps 1-3 to install the keypad overlay (N5242-80005).
5. Repeat steps 1-3 to install the power button overlay (N5242-80007).
6. Install the new nameplate (N5245-80003).

## Step 31. Install the Front Panel Jumper Cables

Install twelve W36 front panel jumper cables (N5245-20104) - use 6 old jumpers and 6 new jumpers. To see an image of the front panel jumper cables, click the Chapter 7 bookmark “Removing and Replacing the Front Panel Assembly” in the PDF Service Guide<sup>1</sup>.

## Step 32. Reinstall the Inner Cover

For instructions, click the Chapter 7 bookmark “Removing the Covers” in the PDF Service Guide<sup>1</sup>.

## Step 33. Reinstall the Outer Cover

For instructions, click the Chapter 7 bookmark “Removing the Covers” in the PDF Service Guide<sup>1</sup>.

## Step 34. Install the Cable Guard

Push the new cable guard (N5242-00030) over the six new front jumper cables until its cushioning material touches the front panel of the PNA.

---

1. See [“Downloading the Online PNA Service Guide” on page 5](#).



## Step 35. Enable Options P04 (400) and 419

### Procedure Requirements

- The analyzer must be powered up and operating to perform this procedure.
- The Network Analyzer program must be running.
- Obtain a license key for installation of this upgrade by following the instructions on the supplied Option Entitlement Certificate.

### Option Enable Procedure

1. To start the option enable utility, press UTILITY **System**, then **Service**, then **Option Enable**. An option enable dialog box will appear.
2. Click the arrow in the **Select Desired Option** box. A list of available options will appear.
3. In the **Select Desired Option** list, click **P04 - 4-Ports**.
4. Using the keyboard, enter the license key in the box provided. The license key is printed on the the license message you received from Agilent. Enter this key *exactly* as it is printed on the message.
5. Click **Enable**.
6. Click **Yes** in answer to the displayed question in the **Restart Analyzer?** box.
7. Repeat steps 3-6 to enable Option 419, clicking **419 - Src/Rcvr Atten & Bias Ts 4-Port** in step 3.
8. When the installation is complete, click **Exit**.

### Option Verification Procedure

Once the analyzer has restarted and the Network Analyzer program is again running:

1. On the analyzer's **Help** menu, click **About Network Analyzer**.
2. Verify that "P04," and "419," are listed after "Options:" in the display. Click **OK**.

---

**NOTE** If the options have not been enabled, perform the "[Option Enable Procedure](#)" again. If the options are still not enabled, contact Agilent Technologies. Refer to "[Getting Assistance from Agilent](#)" on page 3.

---

## Step 36. Perform Post-Upgrade Adjustments and Calibration

### Adjustments

The following adjustments must be made due to the hardware changes of the analyzer.

- default EE
- source adjustment
- receiver adjustment

These adjustments are described in the PNA Service Guide and in the PNA on-line HELP. A list of equipment required to perform these adjustments is also found in the service guide.

After the specified adjustments have been performed, the analyzer should operate and phase lock over its entire frequency range.

### Operator's Check

Perform the Operator's Check to check the basic functionality of the analyzer. For instructions, click the Chapter 3 bookmark "Tests and Adjustments" in the PDF Service Guide<sup>1</sup>.

If you experience difficulty with the basic functioning of the analyzer, contact Agilent. Refer to ["Contacting Agilent" on page 3](#).

### Calibration

Although the analyzer functions, its performance relative to its specifications has not been verified. It is recommended that a full instrument calibration be performed using the analyzer's internal performance test software. To view information on the performance test software, click the Chapter 3 bookmark "Tests and Adjustments" in the PDF Service Guide<sup>1</sup>.

---

1. See ["Downloading the Online PNA Service Guide" on page 5](#).